

PATRIOT DB

THE AFFORDABLE ANSWER

PATRIOT™ DB is the cost-effective solution for 6 Degree-of-Freedom (6DOF) tracking and 3D digitizing from Polhemus, the pioneer in 3D position/orientation measuring devices. A perfect answer for the position/orientation sensing requirements of 3D applications and environments where cost is a primary concern, it's ideal for head tracking, biomechanical analysis, computer graphics, cursor control, and stereotaxic localization.

► FEATURES

► Cost Effective

Provides position/orientation data at a minimum cost.

► Compact

Fits in the drive bay of your PC.

► Ease of Use

Install and operate in minutes.

► Multiple Output Formats

Position in Cartesian coordinates (inches or centimeters); orientation in direction cosines, Euler angles, or quaternions.

► Multiple Sensor Operation

Permits measurement of up to two sensors with a single system. No additional electronic units are required.

► Reliable

Factory calibrated, never needs adjustment.

► Angular Coverage

The sensors are all-attitude.

► Drift-Free

Solid state electronics.

THE FAST AND AFFORDABLE DIGITAL TRACKER

Two Solutions in One

The PATRIOT DB is a 3D digitizer and a dual sensor motion tracker, making it perfect for a wide array of applications requiring medium resolution, accuracy, and range. Computing the position and orientation of a small sensor as it moves through space, PATRIOT DB provides dynamic, real-time measurements of position (X, Y, and Z Cartesian coordinates) and orientation (azimuth, elevation, and roll).

Real-time Measurement

Measuring position and orientation in real time, PATRIOT DB can update data continuously, discretely (point by point), or incrementally. You can mount up to two sensors on heads or hands to capture real-time data for virtual reality or simulator applications. With the optional stylus, you can trace the outline of a physical object or collect polygon facets and get pinpoint accuracy of unlimited X, Y, and Z data points.

A/C Magnetics

Quiet and stable, the system is essentially unaffected by facility power grids. Update rates are always maintained, as A/C magnetics offer the best signal-to-noise ratios and incorporate sophisticated digital signal processing capabilities. In addition, adaptive filtering is available as a standard feature.

► APPLICATIONS

Limited only by your imagination!



PATRIOT DB

COMPONENTS

The PATRIOT DB system includes a System Electronics Unit (SEU), one sensor, and one source. You can expand the system's capabilities simply by adding an additional sensor.

System Electronics Unit

Contains the hardware and software necessary to generate and sense the magnetic fields, compute position and orientation, and interface with the host computer via a USB 2.0 interface.

(20.2 cm) L x (14.6cm) W x (4.1cm) H
Fits into 5.25" PC Drive Bay

Source

The source is the system's reference frame for sensor measurements.

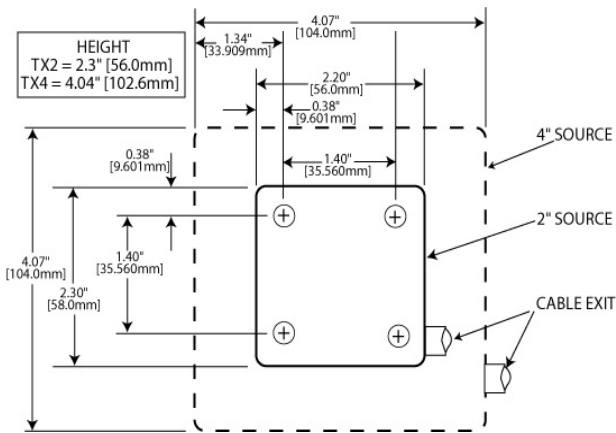

Weight

TX2: 8.8 oz. (250 gm) **Thread size** 1/4" x 20
TX4: 1.60 lbs. (726gm) **Thread size** 1/4" x 20

Sensor

A lightweight, small cube, the sensor's position and orientation is precisely measured as it is moved.

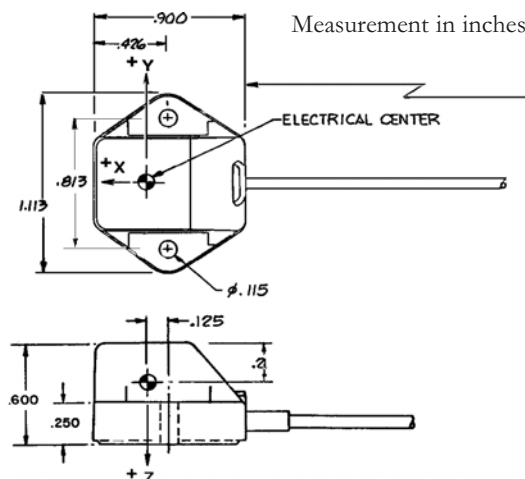

Weight

0.32 oz. (9.1 gm)



The systems are not certified for medical or bio-medical use. Any reference to medical or bio-medical use are examples of what medical companies have done with the systems after obtaining all necessary or appropriate medical certifications. The end user/OEM must comply with all pertinent FDS/CE and all other regulatory requirements.

SPECIFICATIONS

Update Rate

60 Hz per sensor simultaneous sampling

Latency

17 milliseconds

Static Accuracy

0.06 inch RMS for the X, Y, or Z position; 0.40° RMS for sensor orientation.

The system will provide the specified performance in a non-metallic environment when the sensors are within 30 inches of the standard TX2 source (42 inches with the TX4 source). Operation at greater ranges will result in slightly degraded performance.

Interface

USB 2.0 (Back Panel) Cable Included

Range vs. Resolution

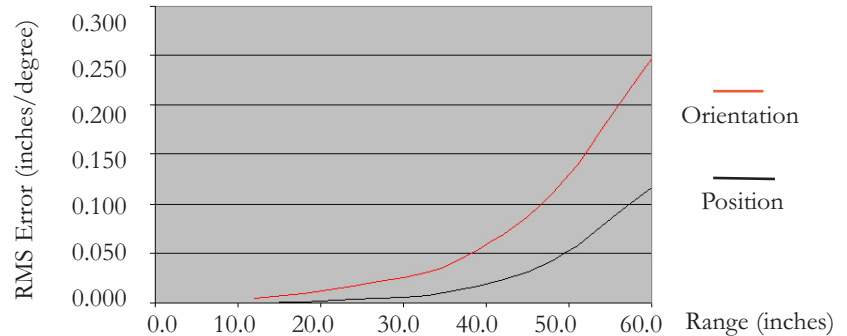

Range (inches)	Position Resolution (inches)	Orientation Resolution (degrees)
12.0	0.00046	0.0038
24.0	0.0035	0.0168
36.0	0.0113	0.0407
48.0	0.0428	0.1108
60.0	0.1175	0.2470

Data Format

Operator selectable ASCII or IEEE 754 binary; English/Metric Units

Software Tools

GUI and SDK included
USB drivers for Windows® XP/Vista® included
Linux® - contact factory

Operating Temperature

10°C to 40°C at a relative humidity of 10% to 95%, noncondensing

Power Requirements

10W, 100-240 VAC, 50-60 Hz
PC power supply through rear panel connector

Regulatory

FCC Part 15, class A
CE: EN61326-1: 1997/A1:1998/A2:2001/A3:2003 emission
EN61326-1: 1997/A1:1998/A2:2001/A3:2003 Immunity

www.polhemus.com

40 Hercules Drive • PO Box 560 • Colchester, Vermont 05446-0560
US and Canada 800.357.4777 • 802.655.3159 • fax 802.655.1439



PATRIOT is a trademark of Polhemus. Windows and Vista are registered trademarks of Microsoft Corp. Linux is a registered trademark of Linus Torvalds. Copyright © 2010 Polhemus MS081 Rev B