

## A REVOLUTION IN ELECTROMAGNETIC TRACKING SCIENCE

SCOμT™ is the only self-contained 6 Degree-of-Freedom (6DOF) head-tracker in the world, and incorporates such features as:

- > Embedded Boresight Retainment
- > Simplified or Eliminated Calibration
- > Advanced Breakaway/Quick Disconnect Management

- ▶ SCOμT is a revolutionary paradigm breakthrough in advanced electromagnetic technology. The system eliminates the need for a system electronics unit. The 6DOF helmet mounted sensor communicates its position and orientation directly to the host PC, image generator, or the fire control computer (FCC). This removes the need to plan for tracker electronics space within an airframe or high fidelity simulator and eliminates the need for sensitive and complicated inter-component wiring.



*Canopy Source and connector*



*Standard Source and connector*

## SELF-CONTAINED μTRACKER

### Two Source Options: Canopy Source and Standard Source

By using the new Polhemus Canopy Source, calibration is either entirely eliminated or greatly simplified for many simulators or other head tracking applications. Polhemus advancements in active A/C magnetic signal generation have produced a miniaturized source (10 grams) which has opened new possibilities for canopy installations.

The Canopy Source also has an extremely small footprint and light-weight characteristics to aid in straightforward cockpit integration. For other installations where the canopy is not a consideration, a slightly larger, more traditional Standard Source is readily available.

### Ultra Lightweight Head Sensor

The entire SCOμT head sensor, cabling and electronics weigh only 35 grams which is consistent with the current magnetic tracking sensor now being used. Because sensor and computational electronics are self contained, sensitive wiring to a breakaway connection for ejection safety is greatly simplified. Only six high level signal wires are required through the breakaway connector.

### Calibration

If environmental conditions require calibration, Polhemus has developed a high-speed calibration capability that has been demonstrated to produce a highly accurate tracking area within a cockpit in less than one hour.



*Helmet Sensor and complete tracker electronics dongle*



*Sensor shown externally on helmet for illustration purposes only*

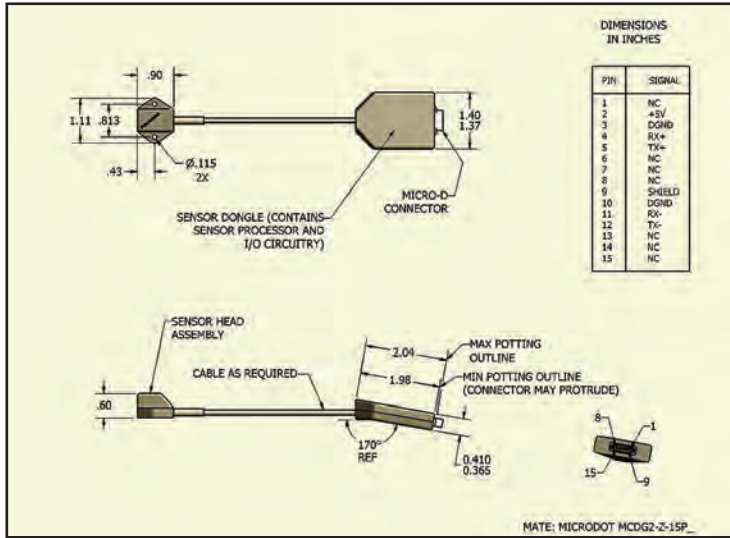

Sensor and tracker electronics dongle

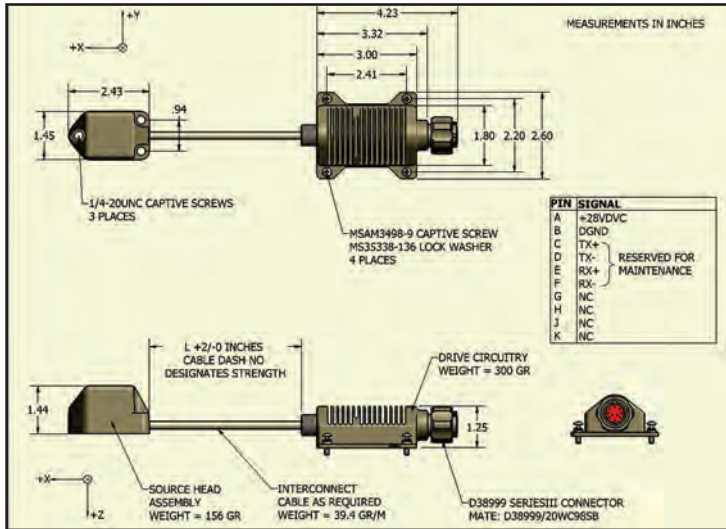

Standard Source and connector

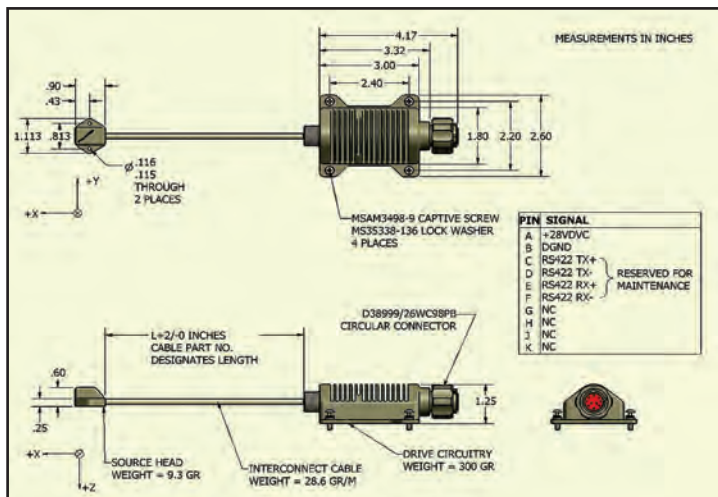

Canopy Source and connector

## SPECIFICATIONS

The system will operate at the specified performance in a metallicly clean environment. Simplified calibration is now available for mitigating the effects of metallic distortion in flight-worthy aircraft and high fidelity simulators.

### Update Rate

240 updates per second

### Latency

3.5 milliseconds

### Interface (Sensor Dongle)

RS-422 (115 KB)

### Static Accuracy

0.18 degrees (3.14mr) RMS for sensor orientation; 0.03 inches (0.8mm) RMS for the X,Y, and Z position

### Resolution

0.00015 inches (0.0038mm) at 12 inches (0.3m); 0.0012 degrees (.021mr) orientation

### Range

36+ inches (.82m) in diameter with the Canopy Source; 60 inches (1.52m) in diameter with the Standard Source

### Angular Coverage

The sensor is all-attitude with no limits

### Slew Rate

Solid state advanced AC magnetics have no slew rate limitation: max/min rate - unlimited

### Physical Characteristics/Signal/Pinouts

See drawings to the left

### Power Requirements

Sensor: 5 VDC, 200 MA (regulated)

Canopy Source: 7 to 36 VDC (1 watt)

Standard Source: 7 to 36 VDC (4 watt)

### Operational Temperatures

Sensor: -20C to +50C (-4F to +122F)

Source: -40C to +70C (-40F to + 158F)

### Mechanicals

The source and sensor microelectronics are fully encapsulated, providing robust physical and mechanical characteristics.

- Non-qualified SCOμT systems available for Simulation & Training
- Limited Safety of Flight Testing Completed
- Contact Polhemus directly for full Qualification Testing discussions

[www.polhemus.com](http://www.polhemus.com)

40 Hercules Drive • PO Box 560 • Colchester, Vermont 05446-0560  
US and Canada 800.357.4777 • 802.655.3159 • fax 802.655.1439

SCOμT is a trademark of Polhemus  
Copyright © 2008 Polhemus. Rev. Oct 2011 ST: MSO66

